

RLMK21 Single Point, Stainless Steel

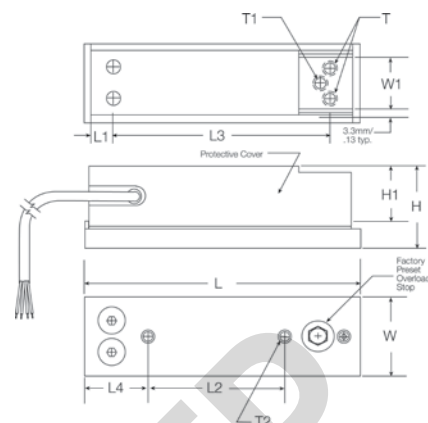

Picture is a representation of actual product



SPECIFICATIONS

Full Scale Output:

2.0mV/V

Bridge Resistance:

350 ohms

Material/Finish:

Stainless steel

Temperature:

Compensated range
0°F to 150°F/-18°C to 65°C

Safe Overload:

500% Full scale

Rated Excitation:

10V DC

Nonlinearity:

0.02% Full scale

Hysteresis:

0.03% Full scale

Insulation Resistance:

>2000 megohms

Seal Type:

Environmentally sealed

Cable Length:

3.1 m/10 ft

Cable Color Code:

Red + Excitation
Black..... - Excitation
Green + Signal
White - Signal
Orange Shield

Warranty:

Two-year limited warranty

DIMENSIONS

RATED CAPACITY	H	H1	L	L1	L2	L3	L4	T	T1	T2	W	W1
lb/inches												
16.53	1.50	1.00	5.25	.44	2.63	4.13	1.20	1/4-20 UNF 2B Thd. x .50 Min. DP	1/4-28 UNF 2B Thru .265 Dia. x .4 DP	1/4-28 UNF Thd.	1.50	1.00
kg/mm												
7.5	38.1	25.4	133.4	11.2	66.8	104.9	30.5	1/4-20 UNF 2B Thd. x 12.7 Min. DP	1/4-28 UNF 2B Thru 6.7 Dia. x 10.2 DP	1/4-28 UNF Thd.	38.1	25.4

ORDER INFORMATION

LOAD RATING	PART #	PRICE
7.5 kg (16.5 lb)	33297	Consult

INTERCHANGEABLE PRODUCTS

MANUFACTURER	MODEL
NCI/Weigh-Tronix®	3270 Series Checkweigher